

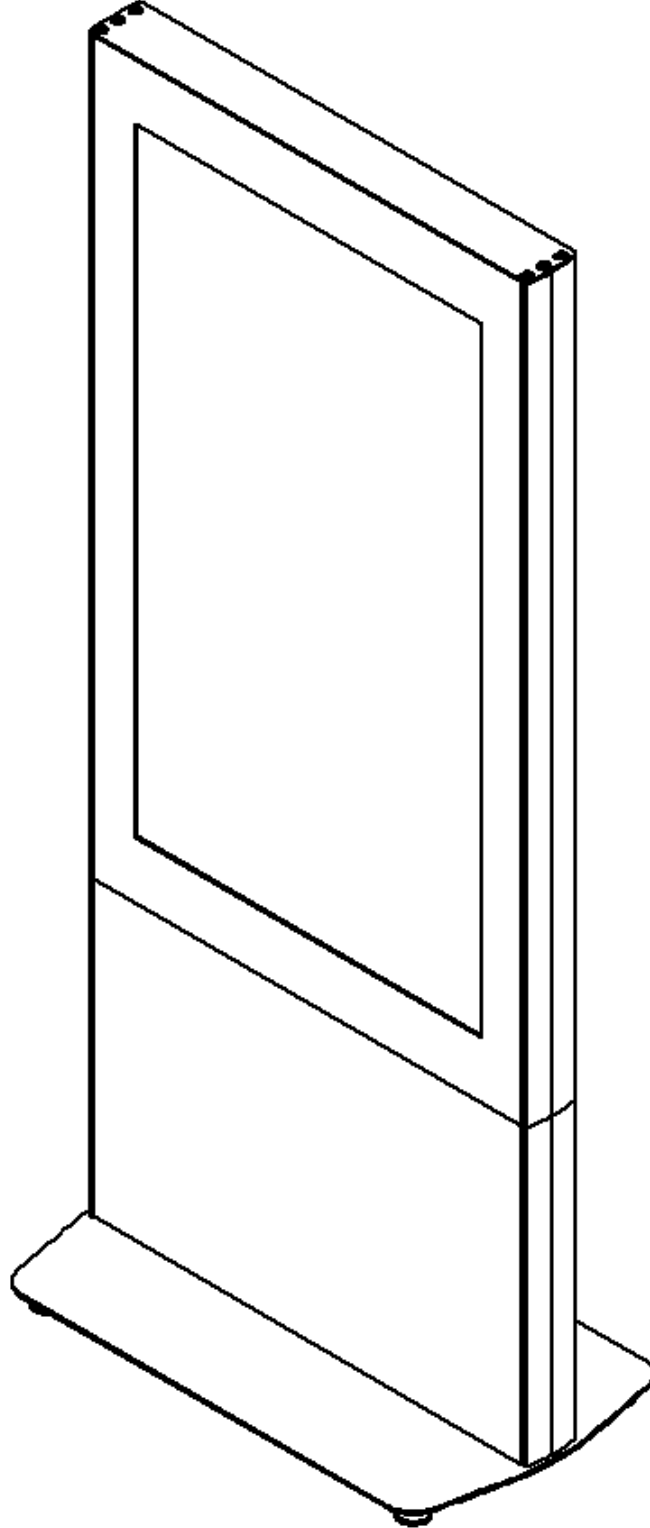

32"-43"-46"-49"-55"-65"-75"

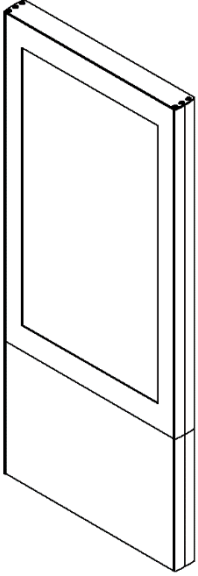
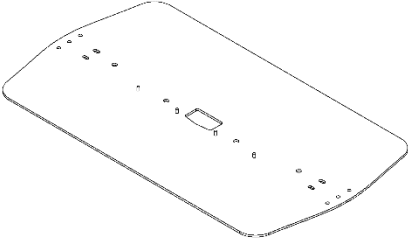
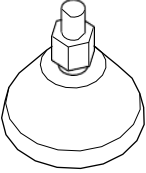

	Main Enclosure <i>Ana Kabin</i>	x1
	Flange <i>Flanş</i>	x1
	Articulated Foot <i>Mafsallı Ayak</i>	x4
	M8x16 Imbus Bolt <i>M8x16 Imbus Cıvata</i>	x4
	M6 Nut <i>M6 Somun</i>	x5
	Key <i>Anahtar</i>	x2
	6 Allen <i>6 Alyan</i>	x1

1

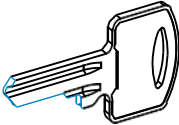
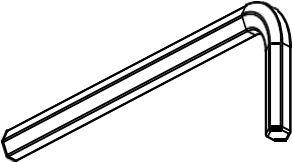
*Open the packaged main cabinet and place it on the table.*  
*Paketlenmiş olan ana kabini açınız ve masanın üzerine yerleştiriniz.*

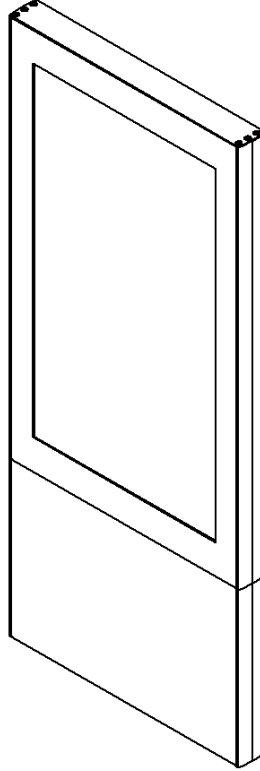

2

*Open the packaged flange and place it on the table.*  
*Paketlenmiş olan flanşı açınız ve masanın üzerine yerleştiriniz.*

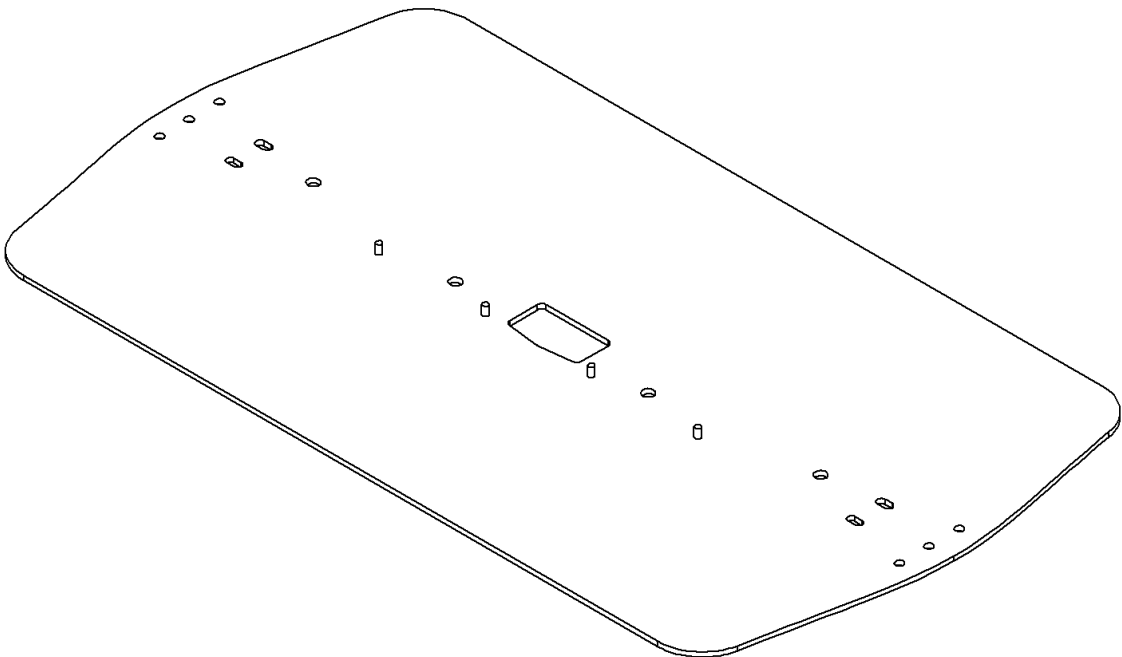

3

As seen in the picture, fix the flange to the main cabinet using M8x20 and M8x16 Imbus head bolts.  
Resimdeki görüldüğü gibi M8x20 ve M8x16 Imbus Başlı civata kullanarak flanşı ana kabine sabitleyiniz.

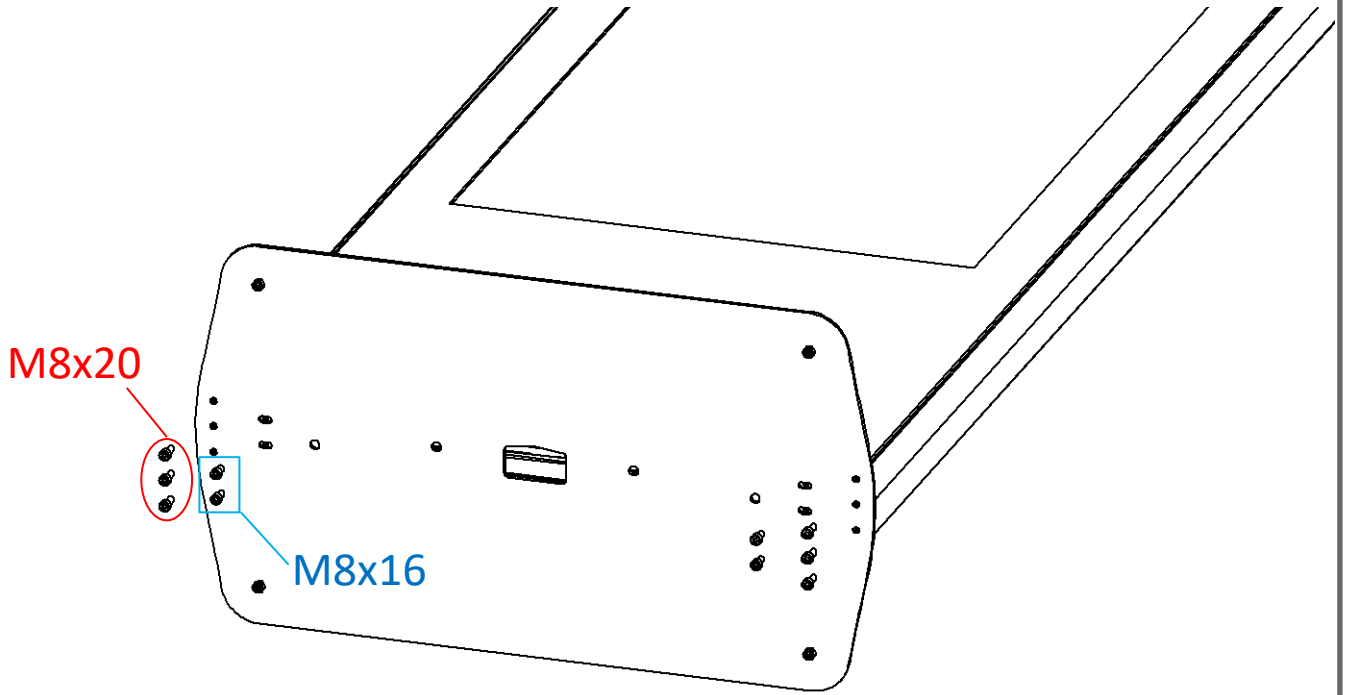

4

Attach the M10 feet to the nuts on the flange as shown in the picture.  
Flansta bulunan somunlara M10 ayakları resimdeki gibi takınız.

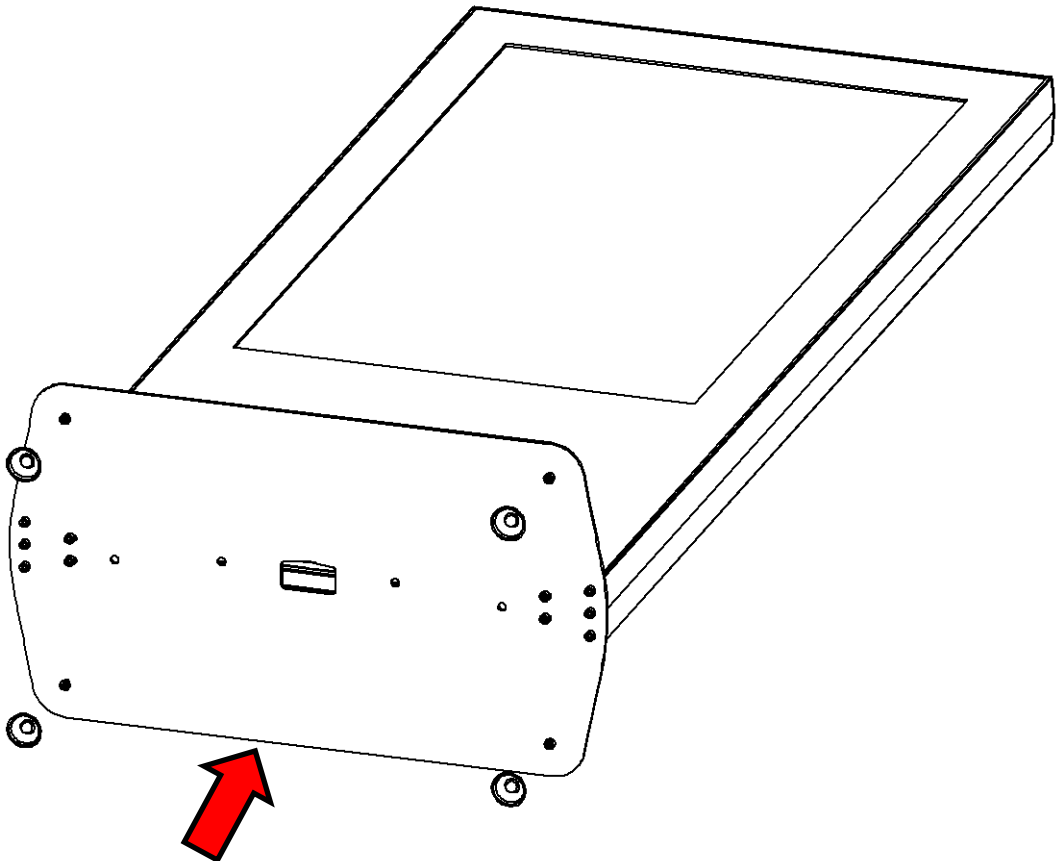

5

*Pull the back cover and open it.*  
*Arka kapağı çekin ve açınız.*

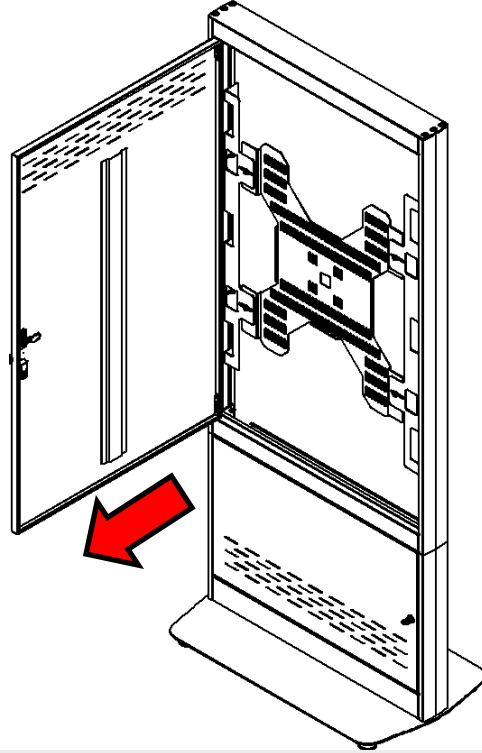

6

*Remove the Imbus Bolts on the suspension brackets to remove the monitor plate.*  
*Monitör sacını çıkartabilmek için askı takozlarındaki Imbus Cıvataları çıkartınız.*

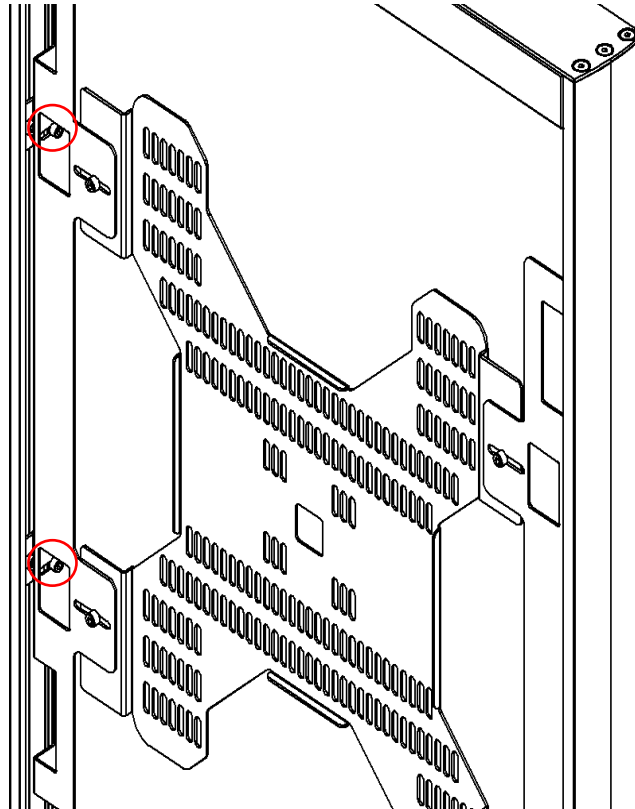

7

*Pull out the Monitor Hanger as shown in the picture.  
Monitör Askısını resimdeki gibi çekip çıkartınız.*

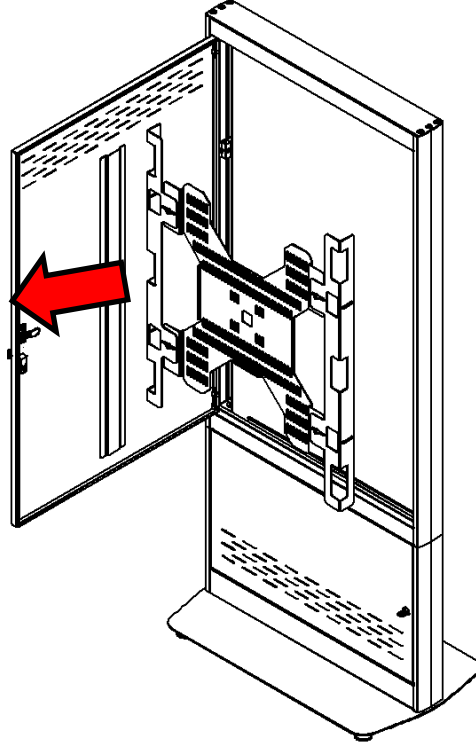

8

*Secure the monitor hanger to the monitor using the appropriate VESA holes.  
Monitör askısını uygun VESA deliklerini kullanarak monitöre sabitleyiniz.*

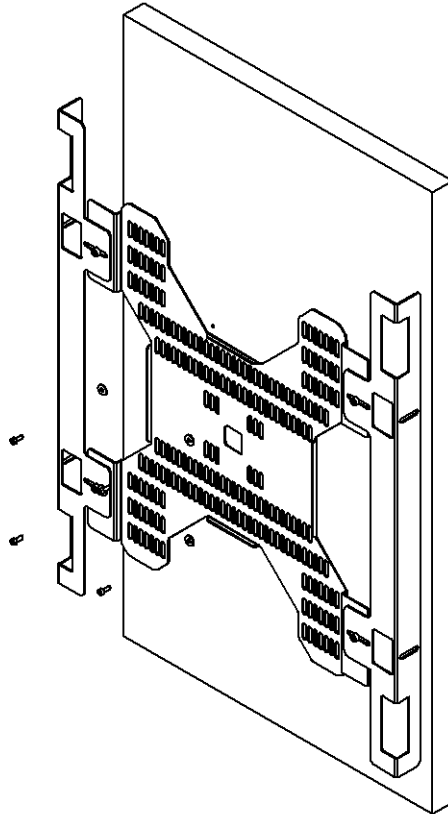

9

Place the Monitor Hanger so that it fits between the hanger blocks between the profiles.  
Monitör Askısını profillerin arasındaki askı takozlarına gelecek şekilde yerleştiriniz.

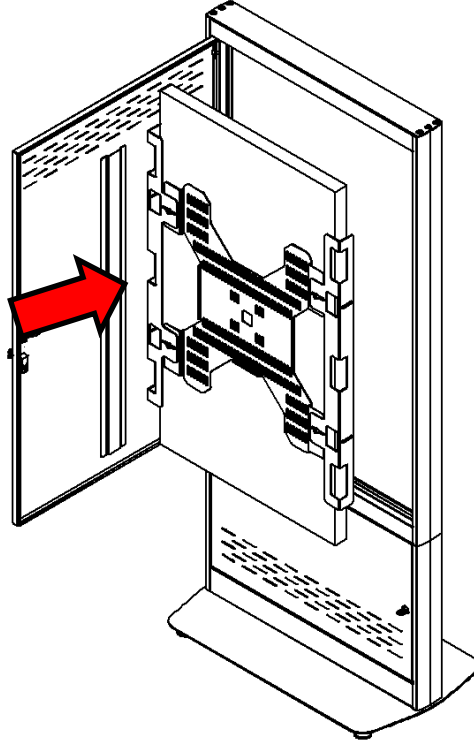

10

To fix the monitor sheet and upright parts, mount the suspension wedges on the upright profiles using M8x16 Hexagon Bolts.  
Monitör sacını ve Dikme parçalarını sabitlemek için dikme profillerinde bulunan askı takozlarını M8x16 İmbus Cıvata kullanarak montaj ediniz.

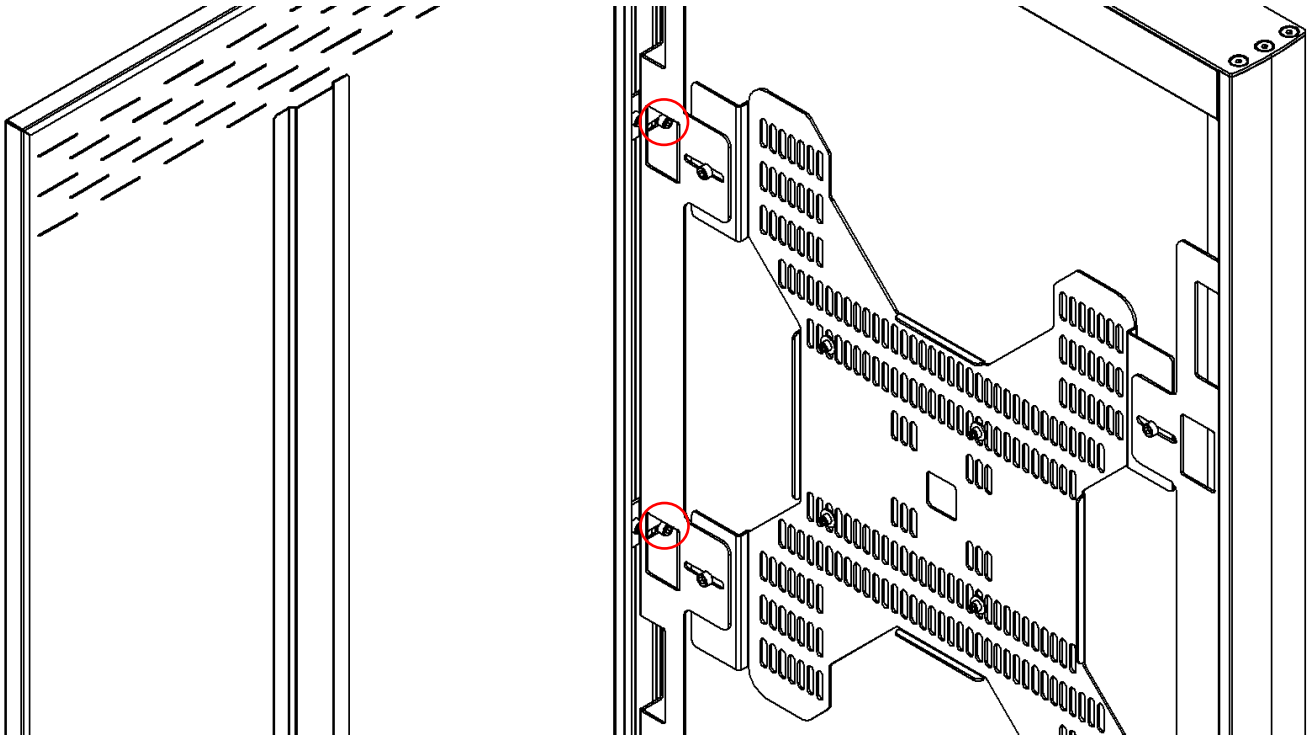

- 11** *Push the back cover and close it.*  
*Arka kapağı iktirin ve kapatınız.*

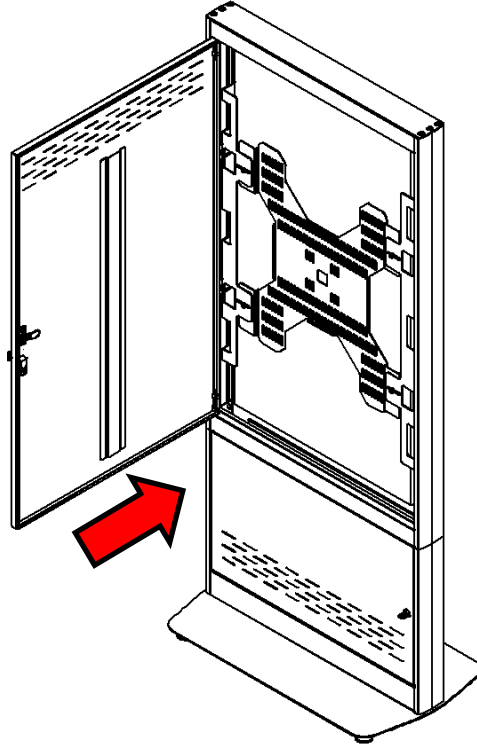

- 12** *Assembly process is completed.*  
*Montaj işlemi tamamlanmıştır.*

